

THREE-PIECE BALL VALVES

H-500 SERIES



H-500 FEATURES

3-piece heavy-duty ball valves with:

- Certified for ISO 15848-1:2006(E)
- Precision Investment cast body in CF8M stainless steel
- Precision Investment cast end caps in CF3M stainless steel
- Blow-out proof stem with Belleville washer design for long life stem sealing
- Manual Operation with integral locking device
- Flow coefficient (Cv) from 1.2 to 24.0
- MAWP 3000 psig (206 Barg), 2000 psig (137 Barg) for “-FP” option
- MAWT 450°F (232°C)
- H-500S seat material is Modified PTFE as standard

MATERIALS OF CONSTRUCTION

No.	Components	Material	Qty
1	Handle	St.St. 304	1
2	Stem Nut	St.St. 304	2
3	Stem Washer	St.St. 316	1
4	Lock Saddle	St.St. 304	1
5	Belleville Washer	St.St. 304	2
6	Gland	St.St. 304	1
7	Stem Packing	MG1241 / PTFE	1
8	Stem Seal	MG1241	2
9	Stem	St.St. 316	1
10	Locking Device	St.St. 316	1
11	Handle Sleeve	Vinyl	1
12	Stop Pin	St.St. 304	1
13	Tightening Bolt	St.St. 304	4
14	End Cap	ASTM A351 Gr. CF3M	2
15	Joint Gasket	PTFE	2
16	Seat	PTFE	2
17	Body	ASTM A351 Gr. CF8M	1
18	Ball	St.St. 316	1
19	Washer	St.St. 316	4
20	Bolt Nut	St.St. 316	4

Note: If seat material other than PTFE is selected, Joint Gasket and Stem Packing are changed accordingly.

GENERAL

The H-500 Series is a moderate-pressure instrumentation Ball Valve for general service and instrumentation panels.

The valves offer large ports for high flow, tight shutoff, long-life service and low operating torque.

The H-500 Series can be used for bi-directional flow, is rated to max. 3000 psig (204 Bar) and performs as on/off service.

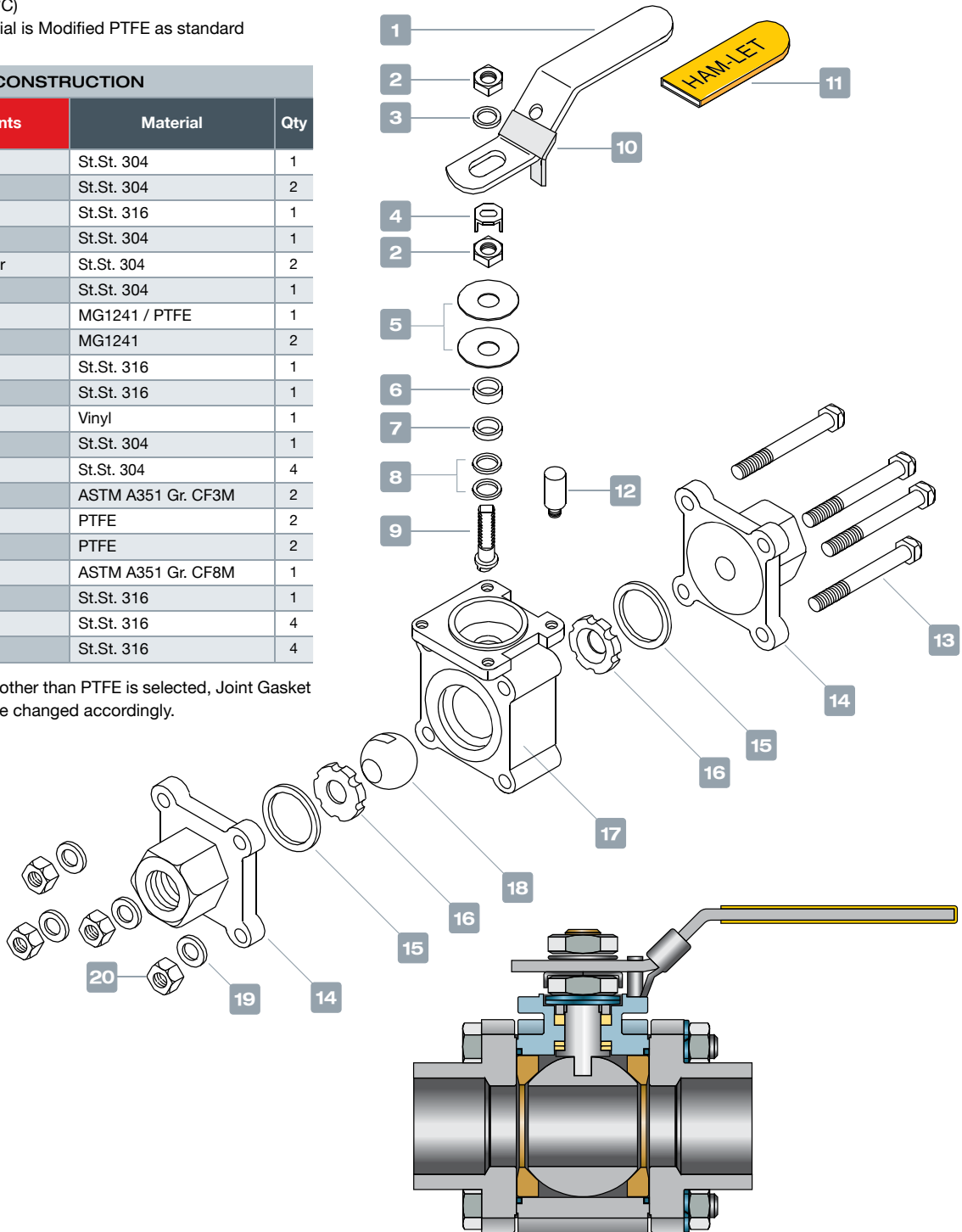

PRESSURE TEMPERATURE RATING

VIRGIN PTFE SEAT

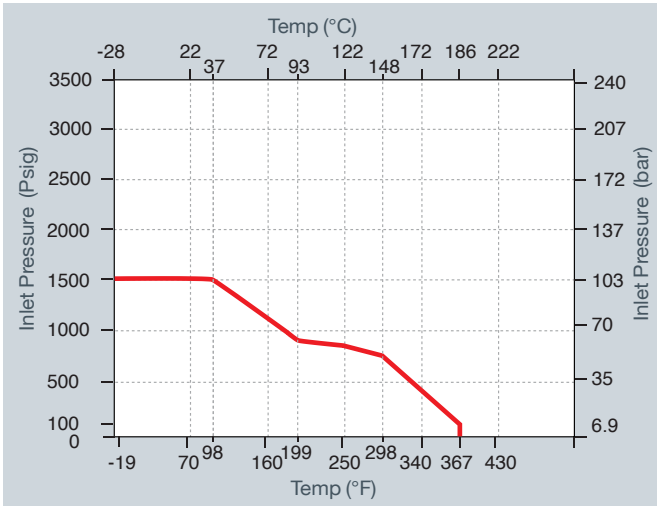

PTFE (Virgin PTFE) Color - White

PTFE is a good all around, general-purpose seat material. PTFE has outstanding resistance to chemical attacks by a broad range of organic chemicals, inorganic chemicals and solvents, and is generally considered chemically inert. PTFE is a self lubricating polymer with a very low coefficient of friction, which makes an excellent seat material

— For all sizes

MODIFIED PTFE SEATS

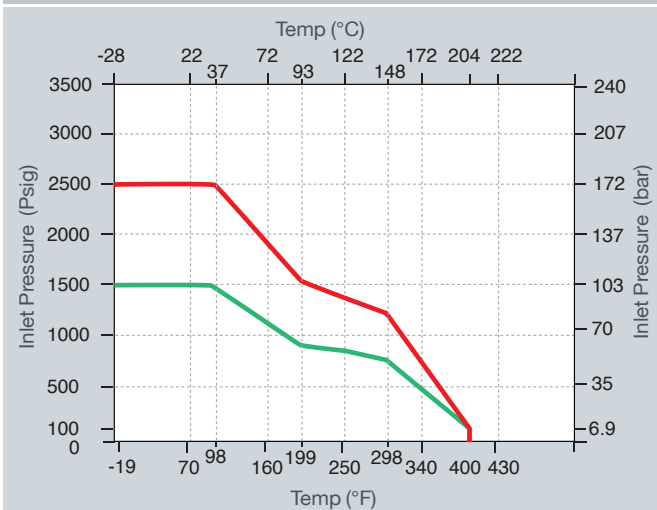

MODIFIED PTFE - (PFA and PTFE composite) Color - Bright White

MODIFIED PTFE is an excellent seat material for purity applications and has very low residual material during operation. It has a lower deformation ratio than PTFE, but a higher pressure and temperature rating than PTFE. Chemical resistance is equal to PTFE material.

— 1/4" to 1" — 1-1/4" to 2"

UHMWPE SEAT

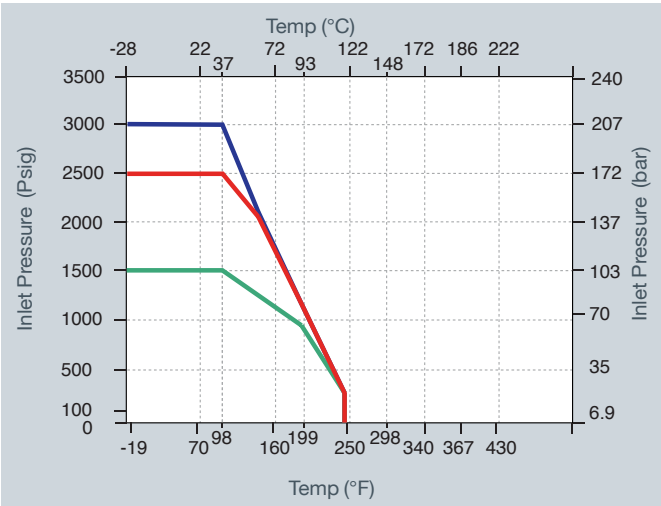

UHMWPE Ultra-high-molecular-weight polyethylene

UHMWPE is a very tough material, highly resistant to corrosive chemicals and suitable for low-radiation service. UHMWPE is self-lubricating, highly resistant to abrasion, has an extremely low moisture absorption and a very low coefficient of friction. UHMWPE meets the requirements for the tobacco industry.

— Up to 1/2" — 3/4" to 1" — 1-1/4" to 2"

PACKING ADJUSTMENT

Due to the varied service applications of the valve, packing adjustment may occasionally be necessary. Packing is factory adjusted to 1000 psig service. Initial packing adjustment is recommended after installation and prior to start-up. Please find more information on H-500 under Installation Instructions.

HAM-LET Ball Valves are designed for operation in the fully closed or fully open position.

TESTING

The H-500 design has been tested for Burst and Proof. Standard testing for each H-500 valve includes testing with nitrogen at 80 & 1000 psig. Each valve is tested for leakage through the shell, packing and ball seats. The maximum allowable leakage across the ball seats is 0.1 std cc/min.

CLEANING & PACKAGING

Every H-500 series ball valve is cleaned in accordance with Standard Cleaning and Packaging (procedure 8184). Oxygen Clean & Lubricant Free Cleaning and packaging, in accordance with Special Cleaning and Packaging (procedure 8185), is available as an option.

Lubricant free cleaned valves have significantly higher actuation torque.

ST. ST. POWDER 50% FILLED PTFE SEATS

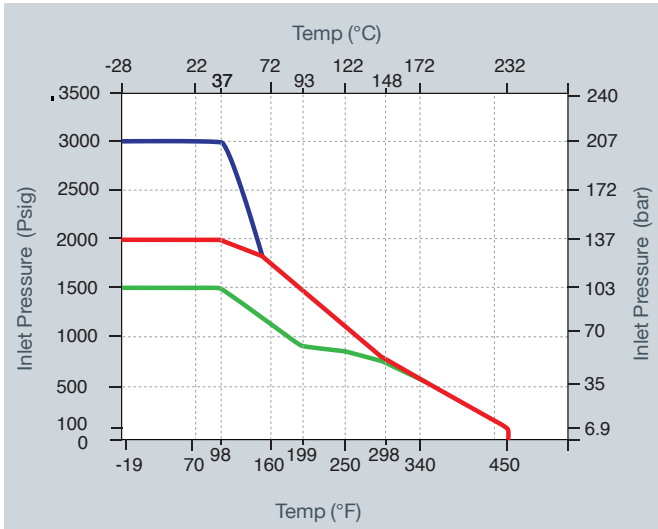

St. St. Powder Filled PTFE Color - Gray

Excellent seat material for general applications to prevent over expansion and seat extrusion. It has a lower deformation ratio than PTFE, but a higher pressure and temperature rating. Chemical resistance is equal to PTFE material.

— Up to 1/2" — 3/4" to 1" — 1-1/4" to 2"

PEEK SEATS

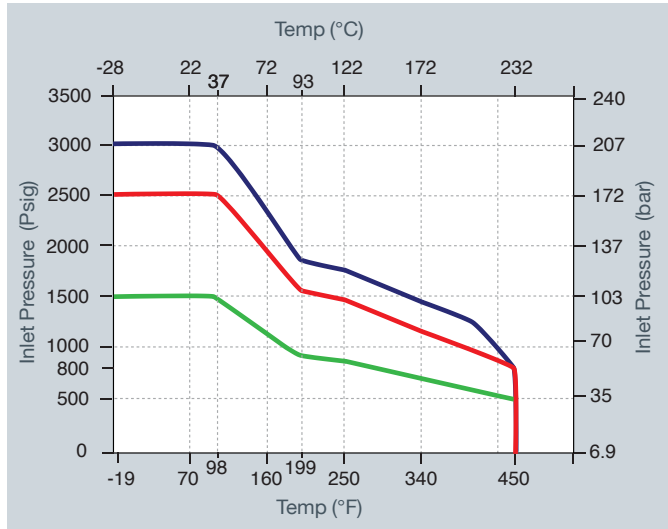

PEEK (Poly Ether Ether Keton) Color - Offwhite

Excellent seat material for high-pressure and high-temperature applications. Excellent chemical resistance. Can be used continuously to 450°F (232°C) and in hot water or steam without permanent loss in physical properties. High strength for hostile environment and high pressure.

— Up to 1/2" — 3/4" to 1" — 1-1/4" to 2"

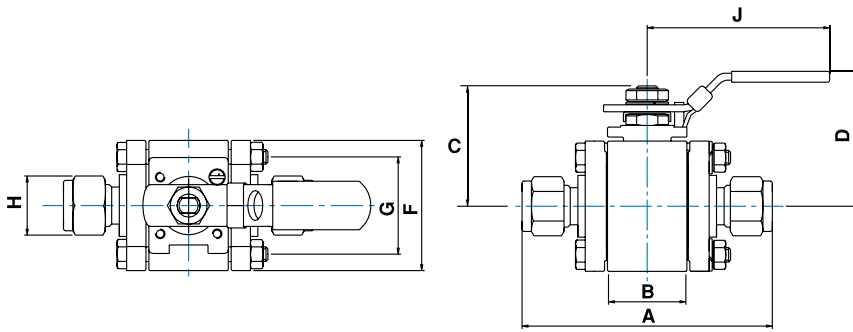

H-500 LET-LOK® STANDARD CONFIGURATION DIMENSIONS

SERIES	End Connection		Orifice		Cv	Ball ID		A		B		F		C		D		H		J		G	
	mm	inch	mm	inch		mm	inch	mm	inch	mm	inch	mm	inch	mm	inch	mm	inch	mm	inch	mm	inch	mm	inch
H-500S	6	1/4"	4.8	0.19	1.2	4.8	0.19	80.5	3.17	15.1	0.59	38.5	1.52	33.2	1.31	48.0	1.89	14.3	0.56	61.0	2.40	25.5	1.00
	10	3/8"	7.1	0.28	3.7	7.1	0.28	80.5	3.17	15.1	0.59	38.5	1.52	33.2	1.31	48.0	1.89	17.5	0.69	61.0	2.40	25.5	1.00
H-500	12	1/2"	10.3	0.40	7.6	11.0	0.43	92.3	3.63	20.6	0.81	44.4	1.75	40.5	1.59	56.5	2.22	22.2	0.87	121.5	4.78	32.0	1.26
	20	3/4"	13.0	0.51	13.6	14.1	0.56	92.7	3.65	24.6	0.97	50.8	2.00	44.0	1.73	60.0	2.36	28.6	1.13	121.5	4.78	38.2	1.50
	25	1"	20.0	0.79	36.0	20.0	0.79	124.4	4.90	31.8	1.25	60.0	2.36	56.7	2.23	74.5	2.93	38.1	1.50	151	5.94	44.0	1.73

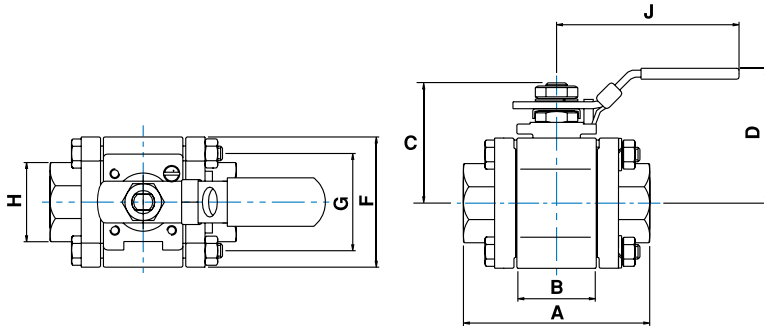

H-510 FEMALE NPT / BSPT STANDARD CONFIGURATION DIMENSIONS

SERIES	End Connection	Orifice		Cv	Ball ID		A		B		F		C		D		H		J		G	
		mm	inch		mm	inch	mm	inch	mm	inch	mm	inch	mm	inch	mm	inch	mm	inch	mm	inch	mm	inch
H-510S	1/4"	7.1	0.28	1.2	7.1	0.28	54.9	2.16	15.1	0.59	38.5	1.52	33.2	1.31	48.0	1.89	19.0	0.75	61.0	2.40	25.5	1.00
	3/8"	11.0	0.43	10	11.0	0.43	70.0	2.76	20.6	0.81	44.4	1.75	40.5	1.59	56.5	2.22	27.0	1.06	121.5	4.78	32.0	1.26
H-510	1/2"	11.0	0.43	10	11.0	0.43	70.0	2.76	20.6	0.81	44.4	1.75	40.5	1.59	56.5	2.22	27.0	1.06	121.5	4.78	32.0	1.26
	3/4"	14.1	0.56	12.0	14.1	0.56	74.0	2.91	24.6	0.97	50.8	2.00	44.0	1.73	60.0	2.36	33.0	1.30	121.5	4.78	38.2	1.50
	1"	20.0	0.79	36.0	20.0	0.79	99.0	3.90	31.8	1.25	60.0	2.36	56.7	2.23	74.5	2.93	42.0	1.65	151	5.94	44.0	1.73

Dimensions are for reference only, and are subject to change without notice.

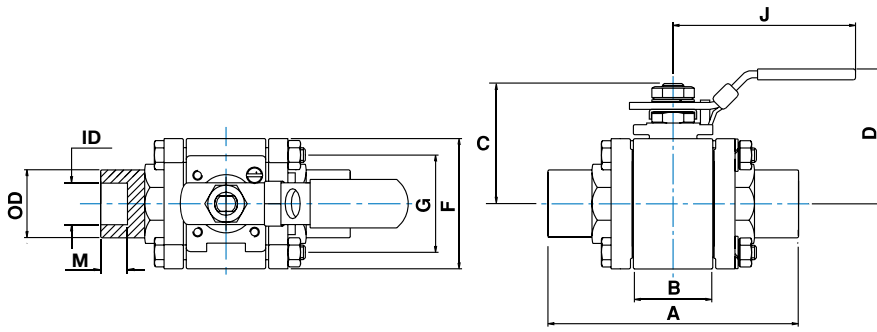

H-510 TUBE SOCKET WELD STANDARD CONFIGURATION DIMENSIONS

SERIES	End Connection		Orifice		Cv	Ball ID		A		B		F		C		D		OD		J		G		ID		M	
	mm	inch	mm	inch		mm	inch	mm	inch	mm	inch	mm	inch	mm	inch	mm	inch	mm	inch	mm	inch	mm	inch	mm	inch	mm	inch
H-510S	6	1/4"	4.8	0.19	1.2	4.8	0.19	54.9	2.16	15.1	0.59	38.5	1.52	33.2	1.31	48.0	1.89	19.0	0.75	61.0	2.40	25.5	1.00	4.80	0.19	7.10	0.28
	10	3/8"	7.1	0.28	3.7	7.1	0.28	54.9	2.16	15.1	0.59	38.5	1.52	33.2	1.31	48.0	1.89	19.0	0.75	61.0	2.40	25.5	1.00	7.10	0.28	7.90	0.31
H-510	12	1/2"	10.3	0.40	7.5	11.0	0.43	70.0	2.76	20.6	0.81	44.4	1.75	40.5	1.59	56.5	2.22	20.5	0.81	121.5	4.78	32.0	1.26	12.85	0.51	12.7	0.50
	20	3/4"	14.1	0.56	12.0	14.1	0.56	74.0	2.91	24.6	0.97	50.8	2.00	44.0	1.73	60.0	2.362	27.0	1.06	121.5	4.78	38.2	1.50	19.2	0.76	14.2	0.56
	25	1"	22.35	0.88	38.0	22.35	0.88	99.0	3.90	31.8	1.25	60.0	2.36	56.7	2.23	74.5	2.93	34.0	1.34	151.0	5.94	44.0	1.73	25.55	1.08	19.2	0.76

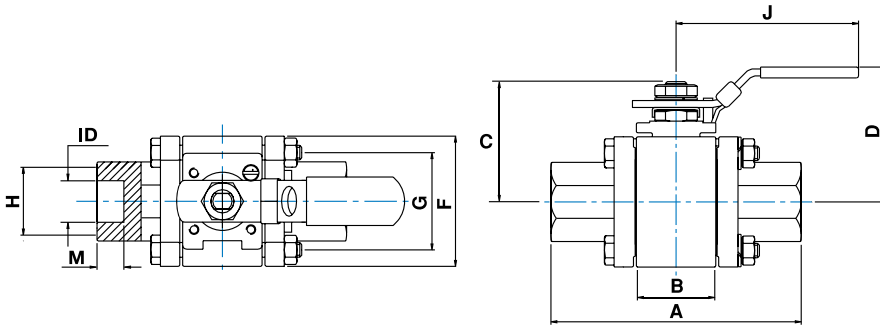

H-510 PIPE SOCKET WELD STANDARD CONFIGURATION DIMENSIONS

SERIES	End Connection	Orifice		Cv	Ball ID		A		B		F		C		D		H		J		G		ID		M	
		mm	inch		mm	inch	mm	inch	mm	inch	mm	inch	mm	inch	mm	inch	mm	inch	mm	inch	mm	inch	mm	inch	mm	inch
H-510	1/4"	11.0	0.43	10	11.0	0.43	70.0	2.76	20.6	0.81	44.4	1.75	40.5	1.59	56.5	2.22	27.0	1.06	121.5	4.78	32.0	1.26	14.1	0.56	9.70	0.38
	3/8"	11.0	0.43	10	11.0	0.43	70.0	2.76	20.6	0.81	44.4	1.75	40.5	1.59	56.5	2.22	27.0	1.06	121.5	4.78	32.0	1.26	17.5	0.69	11.0	0.43
	1/2"	11.0	0.43	10	11.0	0.43	70.0	2.76	20.6	0.81	44.4	1.75	40.5	1.59	56.5	2.22	27.0	1.06	121.5	4.78	32.0	1.26	22.2	0.87	9.50	0.37
	3/4"	14.1	0.56	12.0	14.1	0.56	74.0	2.91	24.6	0.97	50.8	2.00	44.0	1.73	60.0	2.36	33.0	1.30	121.5	4.78	38.2	1.50	27.4	1.08	14.3	0.56
	1"	20.0	0.79	36.0	20.0	0.79	99.0	3.90	31.8	1.25	60.0	2.36	56.7	2.23	74.5	2.93	42.0	1.65	151	5.94	44.0	1.73	34.2	1.35	15.9	0.63

Dimensions are for reference only, and are subject to change without notice.

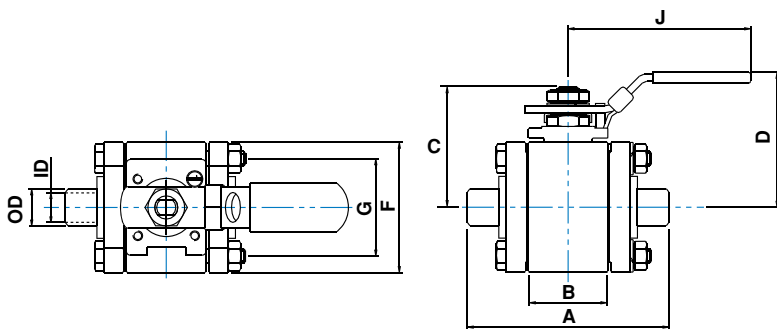

H-580 PIPE BUTTWELD STANDARD CONFIGURATION DIMENSIONS

SERIES	End Connection	Orifice		Cv	Ball ID		A		B		F		C		D		OD		ID		J		G	
		mm	inch		mm	inch	mm	inch	mm	inch	mm	inch	mm	inch	mm	inch	mm	inch	mm	inch	mm	inch	mm	inch
H-580S	1/4"	7.1	0.28	3.7	7.1	0.28	52.8	2.08	15.1	0.59	38.5	1.52	33.2	1.31	48.0	1.89	13.7	0.54	9.20	0.36	61.0	2.40	25.5	1.00
	3/8"	7.1	0.28	3.7	7.1	0.28	52.8	2.08	15.1	0.59	38.5	1.52	33.2	1.31	48.0	1.89	17.1	0.67	10.7	0.42	61.0	2.40	25.5	1.00
H-580	1/2"	11	0.43	10	11.0	0.43	71.6	2.82	20.6	0.81	44.4	1.75	40.5	1.59	56.5	2.22	21.3	0.84	15.8	0.62	121.5	4.78	32.0	1.26
	3/4"	14.1	0.56	12	14.1	0.56	72.0	2.83	24.6	0.97	50.8	2.00	44.0	1.73	60.0	2.36	27.1	1.07	21.0	0.83	121.5	4.78	38.2	1.50
	1"	20	0.79	36	20.0	0.79	97.0	3.82	31.8	1.25	60.0	2.36	56.7	2.23	74.5	2.93	33.4	1.32	26.6	1.05	151	5.94	44.0	1.73

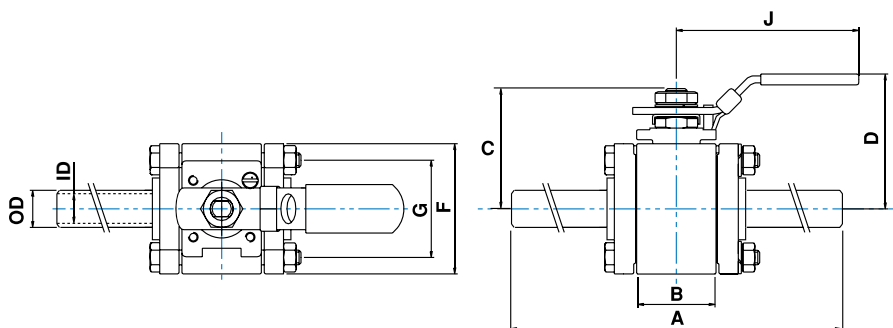

H-580 EXTENDED AND SHORT TUBE BUTTWELD STANDARD CONFIGURATION DIMENSIONS

SERIES	End Connection	Orifice		Cv	Ball ID		A extended		A short		B		F		C		D		OD		J		G		ID	
		mm	inch		mm	inch	mm	inch	mm	inch	mm	inch	mm	inch	mm	inch	mm	inch	mm	inch	mm	inch	mm	inch		
H-580	6 1/4"	4.4	0.17	1	9.4	0.37	-	-	71.5	2.81	20.6	0.81	44.4	1.75	40.5	1.59	56.5	2.22	6.4	0.25	121.5	4.78	32.0	1.26	4.40	0.17
	10 3/8"	7.7	0.3	3.8	9.4	0.37	-	-	71.5	2.81	20.6	0.81	44.4	1.75	40.5	1.59	56.5	2.22	9.57	0.38	121.5	4.78	32.0	1.26	7.70	0.30
	12 1/2"	9.4	0.37	7	9.4	0.37	140	5.5	64.6	2.54	20.6	0.81	44.4	1.75	40.5	1.59	56.5	2.22	12.7	0.5	121.5	4.78	32.0	1.26	9.40	0.37
	20 3/4"	15.75	0.62	18	15.8	0.87	150	5.9	-	-	24.6	0.97	50.8	2.00	44.0	1.73	60.0	2.36	19.05	0.75	121.5	4.78	38.2	1.50	15.75	0.62
	25 1"	22.1	0.87	38	22.35	0.88	161.2	6.35	-	-	31.8	1.25	60.0	2.36	56.7	2.23	74.5	2.93	25.4	1	151	5.94	44.0	1.73	22.1	0.87

Dimensions are for reference only, and are subject to change without notice.

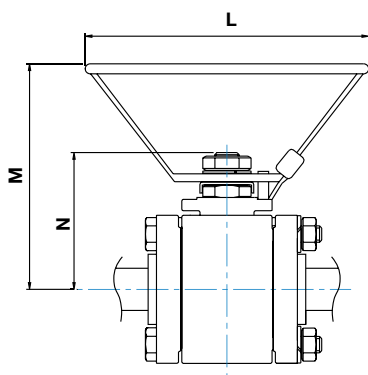

H-500 OVAL HANDLE

End Connection	N		L		M	
	mm	inch	mm	inch	mm	inch
1/4", 3/8", 1/2" 6mm, 10mm, 12mm	40.5	1.6	105.0	4.13	66	2.6
3/4" 20mm	44	1.73	105.0	4.13	70	2.75
1" 25mm	56.7	2.23	105.0	4.13	88.7	3.49

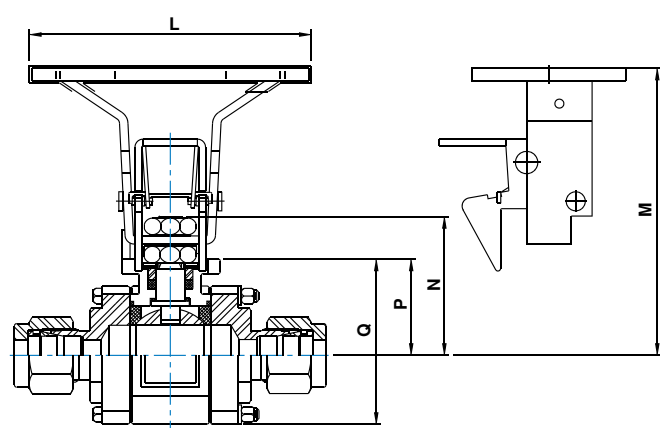

H-500 GRIP HANDLE (OVAL)

End Connection	L		M		N		P		Q	
	mm	inch	mm	inch	mm	inch	mm	inch	mm	inch
1/4", 3/8", 1/2" 6mm, 10mm, 12mm	104	4.09	94.5	3.72	40.5	1.59	27.5	1.08	49.5	1.95
3/4" 20mm	104	4.09	98	3.86	44	1.73	30.5	1.2	56	2.2

Dimensions are for reference only, and are subject to change without notice.

H-500 - PNEUMATIC ACTUATED VALVES

FEATURES

- 90° Actuation for 2-way valves
- Actuators comply with industry standards for interface with ISO 5211, NAMUR and VDI/VDE 3845
- Actuated valves are available factory assembled or separately, actuator and mounting kits
- Limit switches, proximity sensors, position indicators, solenoid valves and other accessories are available upon request
- Standard Temperature range: -32°C to 90°C (-25.6°F to 194°F)
Optional: High Temperature, Low Temperature

MATERIAL OF CONSTRUCTION

No.	Part	Qty	Material
1	Actuator	1	AL 356-T5
2	Coupling	1	St.St.316
3	Bracket	1	St.St.304
4	Washer Flat	4	St.St.304
5	Washer Spring	8	St.St.304
6	Screw	8	St.St.304
7	H500	1	St.St.316

GENERAL

Four standard actuator sizes are available upon request: Mini (designator "A1"), Small (designator "A2"), Medium (designator "A3"), and Large (designator "A4"). Improved operational speed enables better valve opening and closing control. ATEX certification of Valves-Actuators' assemblies are available on request at the time of order quotation.

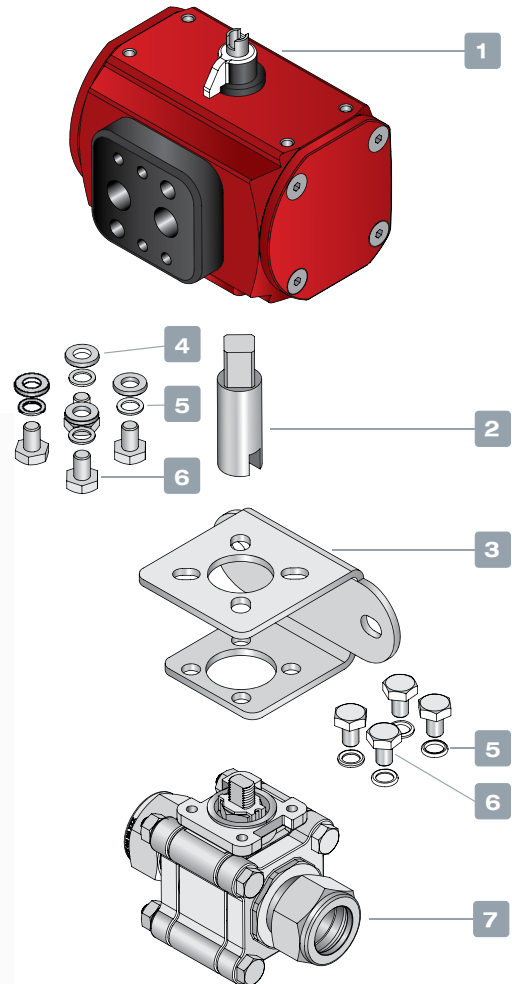

HAM-LET PNEUMATIC ACTUATORS



ACTUATED H-500 SERIES

The selection of Valve-Actuator assemblies provided herein is based on:

- Valve maximum allowable working pressure
- Ambient temperature (50 to 100°F / 10 to 37°C)
- Actuator fits to valve based on operating pressure of 6 bar, in accordance with table A.

To order H-500 ball valve factory assembled with an actuator, the actuator designator shall be added to the valve part number/description per the below table.

Example:

H-500-SS-L-3/4-T with standard Double Acting Aluminum Actuator

H-500-SS-L-3/4-T-A2

To order an actuator and mounting kit for field assembly:

Double Acting Actuator ordering number: **Z-A2**

Corresponding mounting kit: **Z-500-MK-3/4 -F03-F04-A2**

Lubricant free Valves:

For Spring Return Actuator - select one size bigger then offered in the table below.

Example: If the offered actuator in the table is A2C, select A3C

For Double Acting Actuator - please contact your local representative

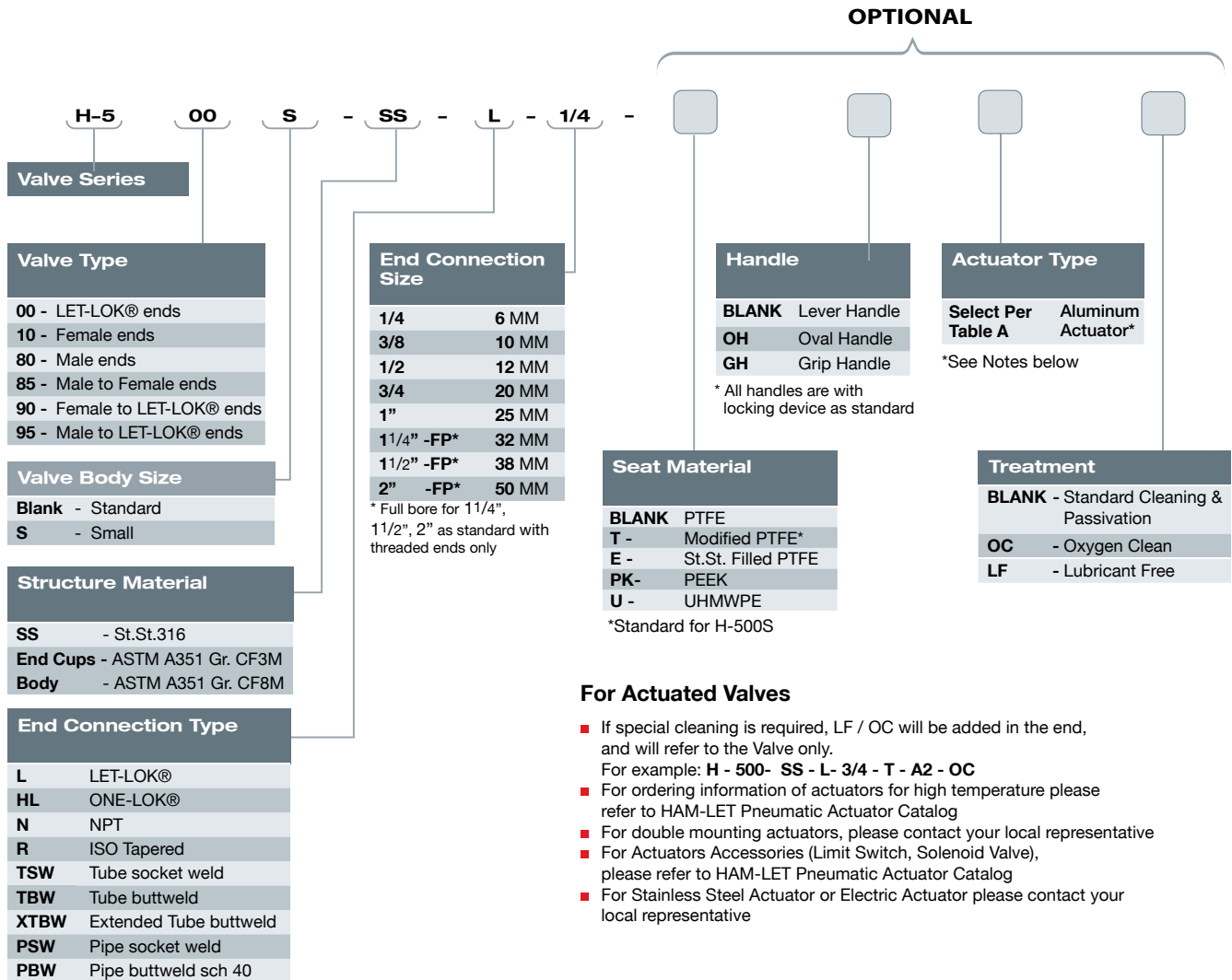

Table A: Ordering information for Actuated Valves

Series	Ends Size	Seats	Minimum Actuator Operating Pressure Bar (Psi)	Actuator Designators (Factory Assembled)			Actuator Ordering Code		Mounting Kit Ordering Info
				Spring Return		Double Acting	Spring Return	Double Acting	
				NO	NC				
H-500S	1/4", 3/8" (6 mm, 10 mm)	Modified PTFE	5 (72.5)	A10	A1C	A1	Z-A1S	Z-A1	Z-500-MK-1/4"-F03-F04-A1
H-500	1/4"-1/2" (6 mm-12 mm)	PTFE Modified PTFE	5 (72.5)	A20	A2C	A1	Z-A2S	Z-A1	SR: Z-500-MK-1/2"-F03-F04-A2 DA: Z-500-MK-1/2"-F03-F04-A1
		St.St. PTFE	5 (72.5)	A20	A2C	A2	Z-A2S	Z-A2	Z-500-MK-1/2"-F03-F04-A2
		PEEK	5 (72.5)	A40	A4C	A3	Z-A4S	Z-A3	SR: Z-500-MK-1/2"-F05-F07-A4 DA: Z-500-MK-1/2"-F04-F05-A3
	3/4" (20 mm)	PTFE Modified PTFE	5 (72.5)	A20	A2C	A2	Z-A2S	Z-A2	Z-500-MK-3/4"-F03-F04-A2
		St.St. PTFE	5 (72.5)	A30	A3C	A2	Z-A3S	Z-A2	SR: Z-500-MK-3/4"-F04-F05-A3 DA: Z-500-MK-3/4"-F03-F04-A2
		PEEK	5 (72.5)	A40	A4C	A4	Z-A4S	Z-A4	Z-500-MK-3/4"-F05-F07-A4
	1" (25 mm)	PTFE Modified PTFE St.St. PTFE	5 (72.5)	A40	A4C	A3	Z-A4S	Z-A3	SR: Z-500-MK-1"-F05-F07-A4 DA: Z-500-MK-1"-F04-F05-A3
		PEEK	5 (72.5)	A50	A5C	A4	Z-A5S	Z-A4	SR: Z-500-MK-1"-F05-F07-A5 DA: Z-500-MK-1"-F05-F07-A4

Note: For dimensions of Actuators assembled on the H-500 series, please refer to the HPA section.

H-500 SERIES ORDERING INFORMATION



ORDERING INFORMATION FOR SEAL KITS

The kit includes gaskets, seats, stem packing and stem seal.

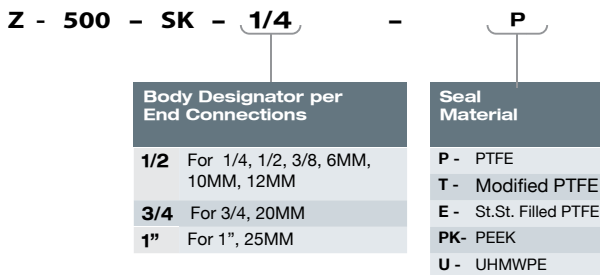

ORDERING INFORMATION FOR HANDLE KITS

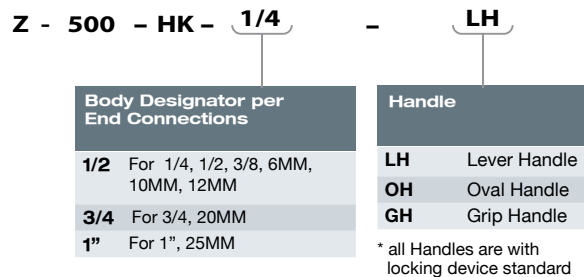

Warning!

The system designer and user have the sole responsibility for selecting products suitable for their special application requirements, ensuring their safe and trouble-free installation, operation, and maintenance. Application details, material compatibility and product ratings should all be considered for each selected product. Improper selection, installation or use of products can cause property damage or personal injury.